

Title		
<Title>		
Size	Document Number	Rev
A	<Doc>	<RevCode>
Date: Wednesday, March 30, 2005		Sheet 1 of 1

NIM to LVDS CONVERTER

MINUS 5V REGULATOR

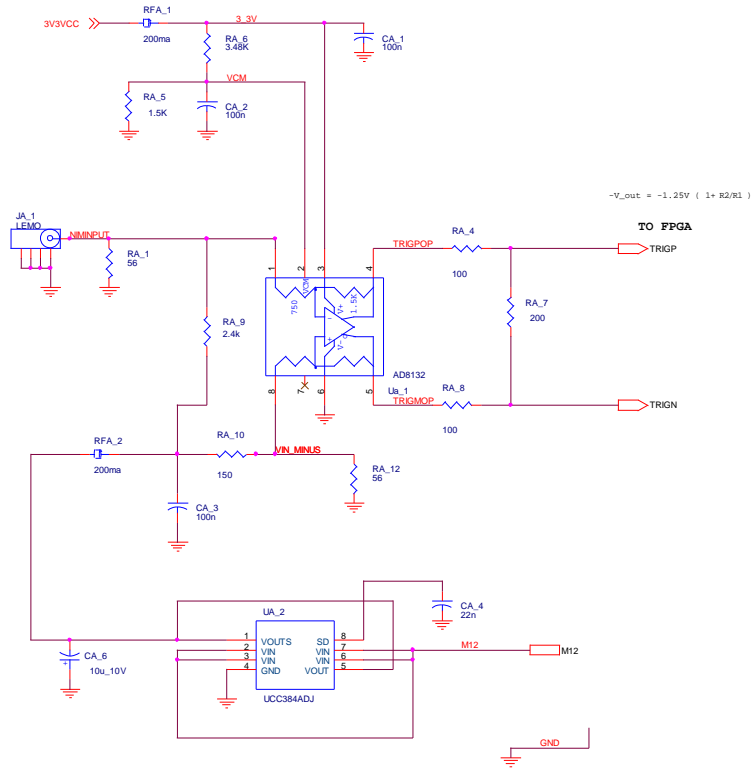

$$-V_{out} = -1.25V (1 + R2/R1)$$

Title		KOPIQ, NIM TO LVDS CONVERTER	
Size	Document Number	Rev	Code
B	TRIGGER		<RevCode>
Date:	Monday, October 30, 2006	Sheet	1 of 1

JTAG PROGRAMMING AND STRATIX CONFIGURATION

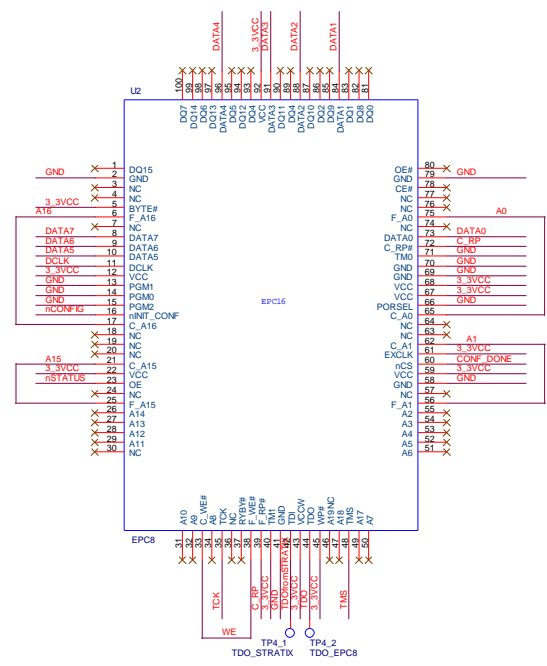
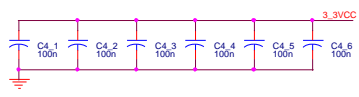
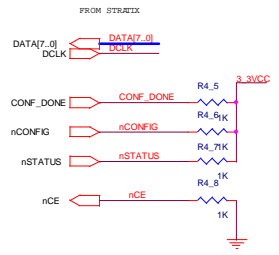
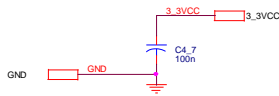
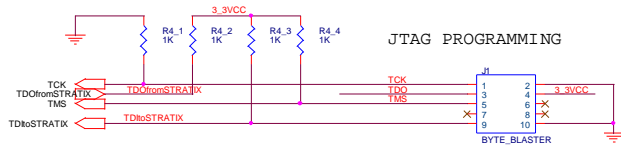

Christian Mercier
 TECHNOLOGIES GROUPS
 Title: TIGRESS
 Size B Document Number CONFIG Rev 0
 Date: Friday, September 03, 2004 Sheet 2 of 9

FRONT PANEL CONNECTORS - RJ45

12 CONNECTOR PAIRS

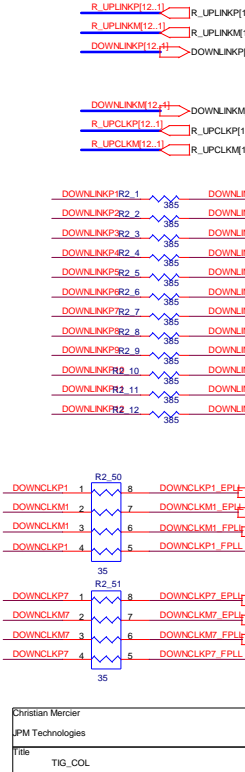
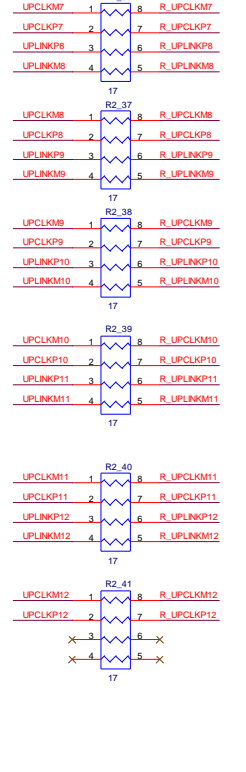
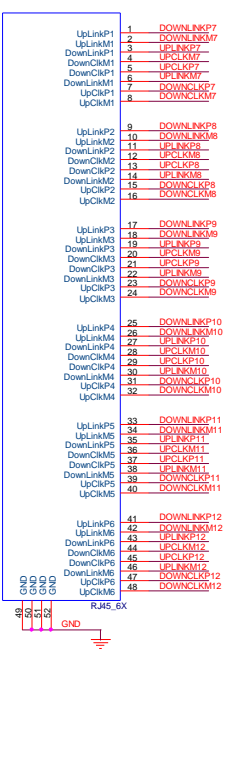
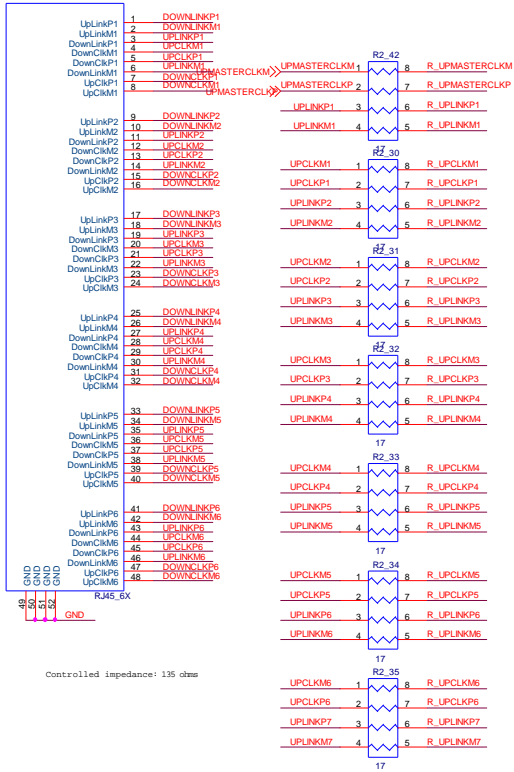

Christian Mercier			
IPM Technologies			
File: TIG_COL			
Size: B	Document Number: front_panel	Rev: 0	
Date: Wednesday, April 06, 2005	Sheet: 3	of 9	

FRONT PANEL CONNECTORS, LEDS AND SYSTEM CLOCK

Impedances: 6 mils separe par 6.5 mils, avec plan a 12 mils: environ 115-130 ohms

REMOTE: DOWNCLK ET LOCLK
PAR LA LIGNE
LOCAL: DOWNCLK PAR LA LIGNE ET
LOCLK DI CRISTAL

CLOCK SOURCE JUMPER

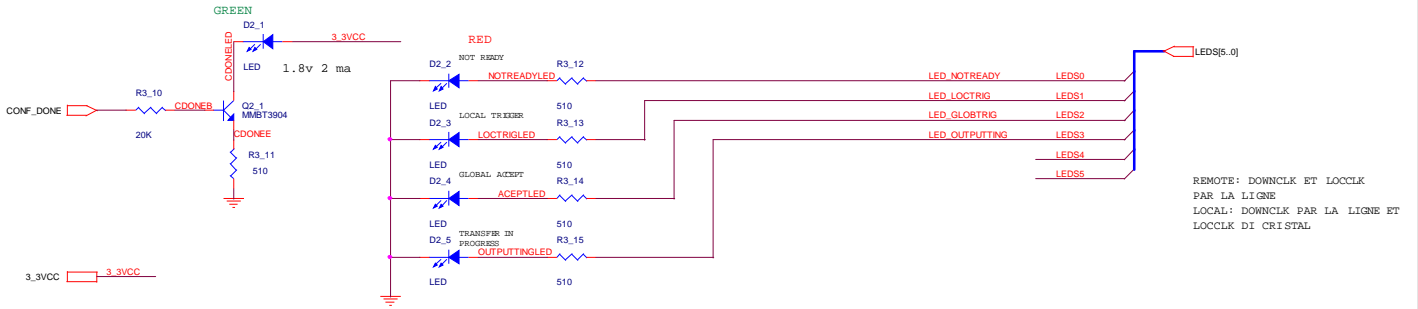
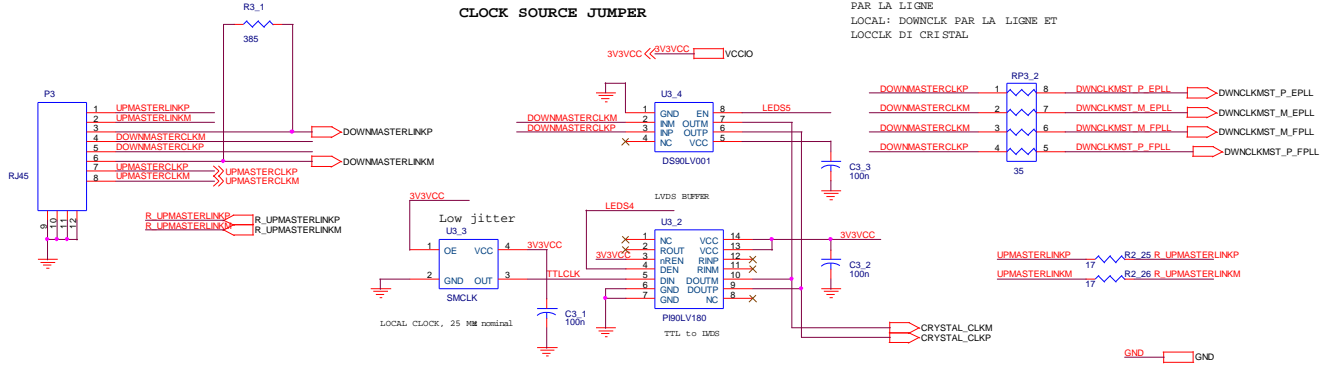

REMOTE: DOWNCLK ET LOCLK
PAR LA LIGNE
LOCAL: DOWNCLK PAR LA LIGNE ET
LOCLK DI CRISTAL

File	<Title>	
Size	Document Number	Rev
B	<Doc>	<RevCode>
Date:	Thursday, November 09, 2006	Sheet 4 of 9

POWER REGULATORS

$$V_{out} = V_{ref} (1 + R2/R1 + I_{adj} R2)$$

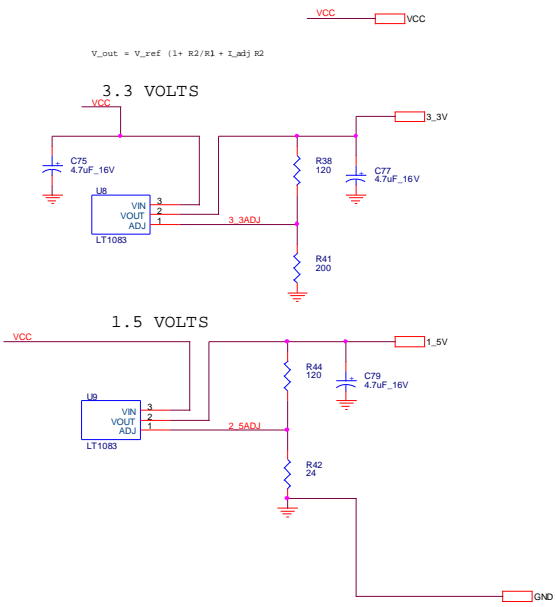

Title		<Title>	
Size	Document Number	Rev	<Rev>
B	POWER		
Date:	Wednesday, March 30, 2005	Sheet	5 of 9

SDRAM CONNECTION

RAM_D[31..0] DQ[31..0]

RAM_CLK CLK
 RAM_CKE CKE
 RAM_WEn WEn
 RAM_CASn CASn
 RAM_RASn RASn
 RAM_CSn CSn

RAM_DQM[3..0] DQM[3..0]

RAM_BA[1..0] BA[1..0]

RAM_A[11..0] A[11..0]

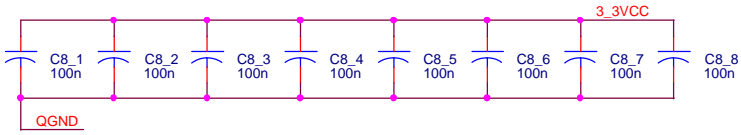
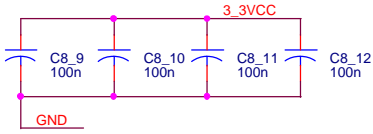
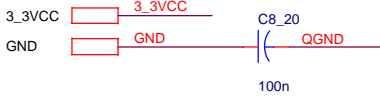

U1				
3_3VCC	1	VDD	86	GND
DQ0	2	VSS	85	DQ15
3_3VCC	3	VDDQ	84	QGND
DQ1	4	VSSQ	83	DQ14
DQ2	5	DQ2	82	DQ13
QGND	6	VSSQ	81	3_3VCC
DQ3	7	VDDQ	80	DQ12
DQ4	8	DQ4	79	DQ11
3_3VCC	9	VDDQ	78	QGND
DQ5	10	VSSQ	77	DQ10
DQ6	11	DQ6	76	DQ9
QGND	12	VSSQ	75	3_3VCC
DQ7	13	VDDQ	74	DQ8
	14	DQ8	73	
3_3VCC	15	NC	72	GND
DQM0	16	VSS	71	DQM1
WEn	17	DQM0	70	
CASn	18	WE#	69	
RASn	19	CAS#	68	CLK
CSn	20	RAS#	67	CKE
A11	21	CS#	66	A9
BA0	22	NC	A9	A8
BA1	23	BA0	A8	A7
A10	24	BA1	A7	A6
A0	25	A10	A6	A5
A1	26	A0	A5	A4
A2	27	A1	A4	A3
DQM2	28	A2	A3	DQM3
3_3VCC	29	DQM2	59	DQM3
	30	VDD	58	GND
DQ16	31	VSS	57	DQ31
QGND	32	NC		
DQ17	33	DQ16	56	3_3VCC
DQ18	34	VSSQ	55	DQ30
3_3VCC	35	DQ17	54	DQ29
DQ19	36	DQ18	53	DQ28
DQ20	37	VSSQ	52	QGND
QGND	38	VDDQ	51	DQ27
DQ21	39	DQ19	50	3_3VCC
3_3VCC	40	DQ20	49	DQ26
DQ22	41	VSSQ	48	DQ25
3_3VCC	42	DQ21	47	QGND
DQ23	43	DQ22	46	DQ24
		VDDQ	45	GND
		DQ23	44	
		VSS		

MT64LC2M32B2

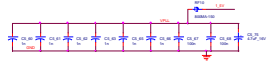
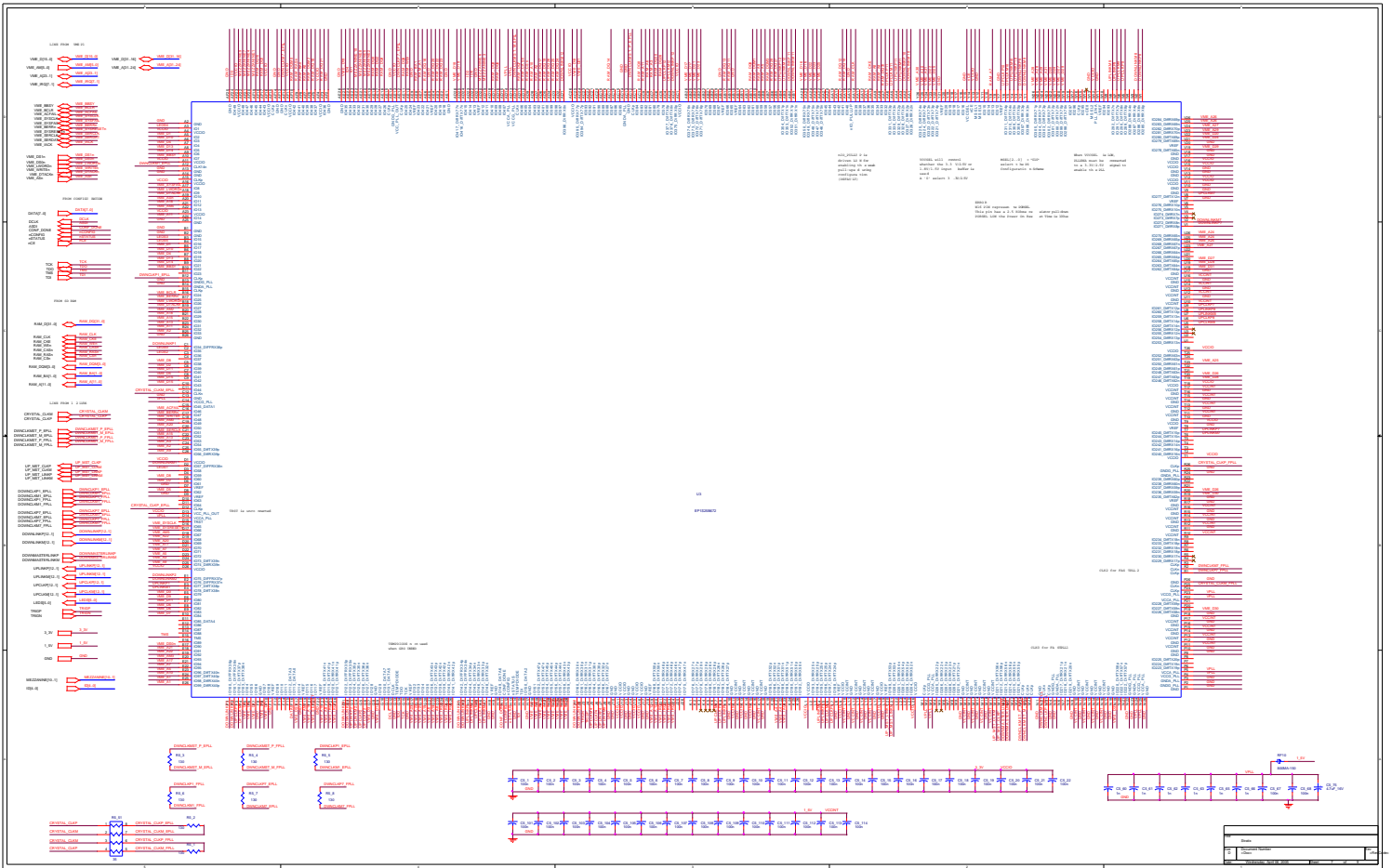

Title		
SDRAM CONNECTION		
Size	Document Number	Rev
A	<Doc>	<RevCode>
Date:	Friday, September 03, 2004	Sheet 6 of 9

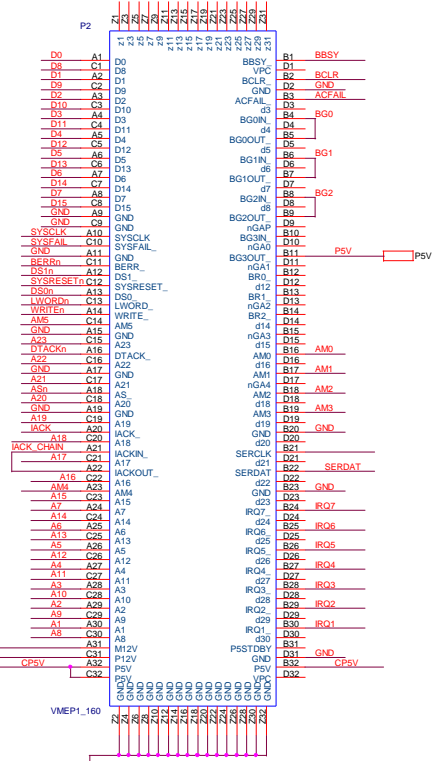
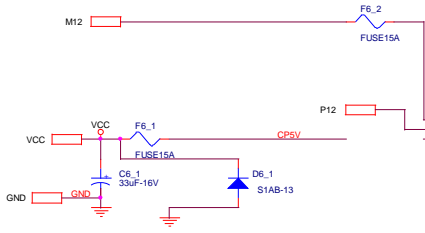
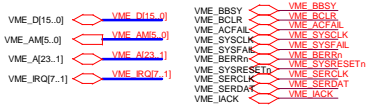
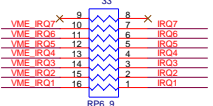
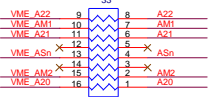
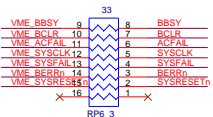
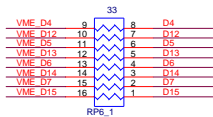

Rev	Date	By	Appr
1			

VME P1 CONNECTION



VME_D[31..16]  VME_D[31..16]
 VME_A[31..24]  VME_A[31..24]

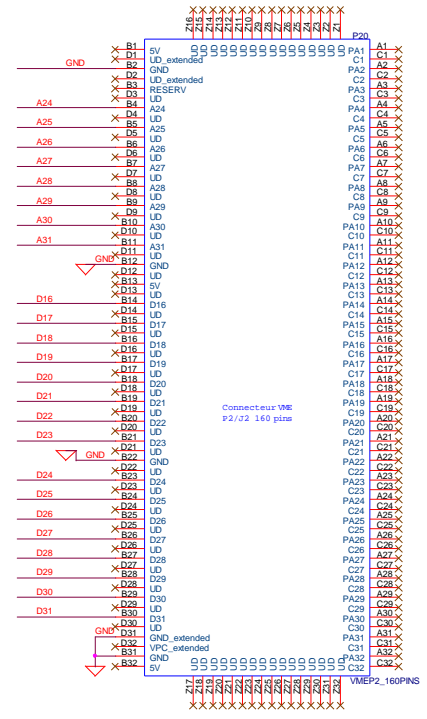
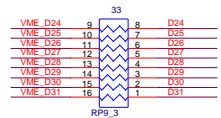
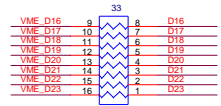

Connecteur VME
P2/P2 160 pins

Groupe technologique			
Christian Mercier			
file			
Tigress Collector			
Size	Document Number		Rev
B	VMEP2		<RevCode>
Date:	Monday, November 22, 2004	Sheet	9 of 9